

REFLECTION  
**LEDKO**<sup>TM</sup>  
*VariWhite Series 2*

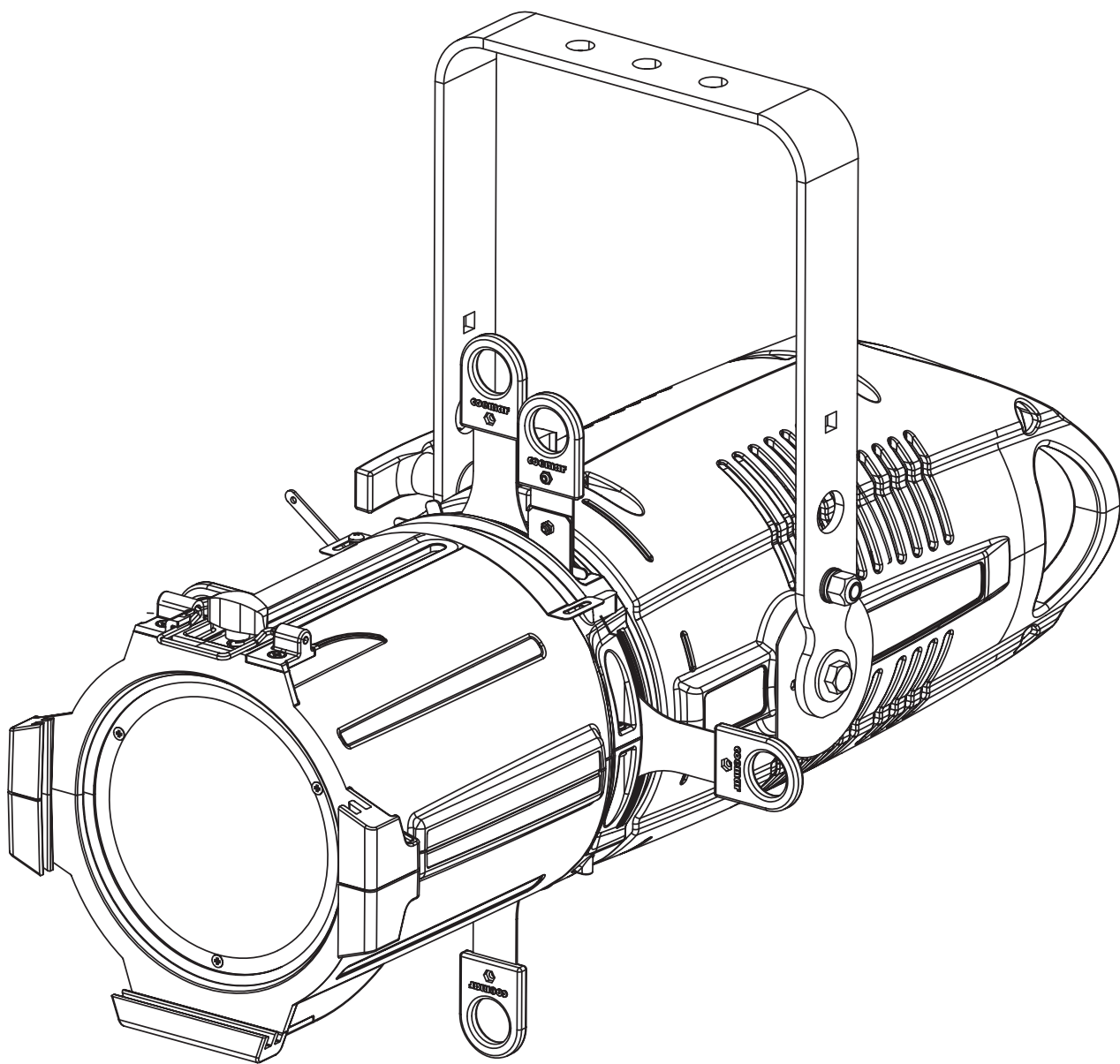

instruction manual  
Version 3.0

# REFLECTION **LEDKO**<sup>TM</sup> *VariWhite Series 2*

Serial Number:

.....

Purchase date:

.....

Dealer:

.....

Address:

.....

Suburb:

.....

Country:

.....

Phone / Fax:

.....

Please note in the space provided above the relative service information of the model and the retailer from whom you purchased your **LEDko VariWhite Series 2**: this information will assist us in providing spare parts, repairs or in answering any technical enquiries with the utmost speed and accuracy.

**WARNING:** the security of the fixture is granted only if these instructions are strictly followed; therefore it is absolutely necessary to keep this manual.

**User Manual version 3.0**

Edition January 2019

# Index

<b>1. Packaging and transportation</b> .....	Pag. 5
<b>1.1</b> Packaging .....	Pag. 5
<b>1.2</b> Transportation .....	Pag. 5
<b>2. General information</b> .....	Pag. 5
<b>2.1</b> Safety informations .....	Pag. 5
<b>2.2</b> Warranty conditions .....	Pag. 6
<b>2.3</b> EC norms .....	Pag. 6
<b>3. Product specifications</b> .....	Pag. 7
<b>3.1</b> Technical characteristics .....	Pag. 7
<b>3.2</b> Dimensions .....	Pag. 7
<b>3.3</b> Unit's main components .....	Pag. 8
<b>3.4</b> Back panel description .....	Pag. 9
<b>4. Installation</b> .....	Pag. 10
<b>4.1</b> Optical Installation .....	Pag. 11
<b>4.2</b> Mechanical installation .....	Pag. 11
<b>4.3</b> Safety chain .....	Pag. 11
<b>4.4</b> Adjusting unit's tilt .....	Pag. 11
<b>5. Powering up</b> .....	Pag. 12
<b>5.1</b> Operating voltage and frequency .....	Pag. 12
<b>5.2</b> Connection to mains power .....	Pag. 12
<b>6. Control signal connections</b> .....	Pag. 14
<b>6.1</b> Control signal connection by XLR5 plugs .....	Pag. 14
<b>7. Turning on the projector</b> .....	Pag. 15
<b>7.1</b> DMX address of the unit .....	Pag. 15
<b>8. DMX Chart</b> .....	Pag. 16
<b>8.1</b> DMX Chart 6 channels .....	Pag. 16
<b>8.2</b> DMX Chart 2 or 1 channels .....	Pag. 18
<b>9. Display panel functions</b> .....	Pag. 19
<b>9.1</b> Quick guide to menu .....	Pag. 19
<b>9.2</b> Rapid count .....	Pag. 19
<b>9.3</b> Main functions menu .....	Pag. 20
<b>9.4</b> Measure (MEAS) .....	Pag. 22
<b>9.5</b> Electronic alignment of the LEDs .....	Pag. 24
<b>9.6</b> Special functions of the fixture .....	Pag. 25
<b>9.7</b> Error messages .....	Pag. 25
<b>10. Accessories and spare parts</b> .....	Pag. 26

<b>11. Maintenance</b> .....	Pag. 28
<b>11.1</b> Firmware update .....	Pag. 28
<b>11.2</b> Periodic cleaning .....	Pag. 28
<b>11.3</b> Periodic controls .....	Pag. 28
<b>11.4</b> Fuses .....	Pag. 28
<b>12. F.A.Q. and answers</b> .....	Pag. 29

Congratulations on having purchased a **Coemar** product. You have assured yourself of a fixture of the highest quality, both in componentry and in the technology used. We renew our invitation to you to complete the service information on the previous page, to expedite any request for service information or spares (in case of problems encountered either during, or subsequent to, installation). This information will assist in providing prompt and accurate advice from your **Coemar** service centre. Following the instructions and procedures outlined in this manual will ensure the maximum efficiency of this product for years to come.

# 1. Packaging and transportation

## 1.1 Packaging

Open the packaging and make sure that no part of the equipment has suffered any damage during the transportation. In case of damage to the fixture, contact your carrier and your supplier immediately by telephone, fax or email, and inform them you will formally notify them in writing through registered letter.

### Packing list

Ensure the packaging contains:

- 1 Reflection LEDko VariWhite Series 2**
- 1 Instruction manual**
- 1 Main power plugs**

## 1.2 Transportation

The **LEDko VariWhite Series 2** should be transported in either its original packaging or in an appropriate flight case.

# 2. General information

## 2.1 Safety informations

### Fire prevention:



1. Never locate the fixture on any flammable surface.
2. Minimum distance from flammable materials: 0,5m.
3. Minimum distance from the closet illuminable surface: 0,5m.
4. Replace any blown or damaged fuse only with those of identical values. Refer to the schematic diagram if there is any doubt.
5. Connect the projector to mains power protected by a thermal magnetic circuit breaker.

### Prevention from electric shock:



1. Presence of high voltage inside of the fixture. Insulate the projector from mains supply before opening or performing any function which involves touching the inside of the fixture, including lamp replacement.
2. For the connection to the mains, adhere strictly to the guidelines outlined in this manual.

3. The level of technology of **LEDko VariWhite Series 2** requires the use of specialised personnel for all service applications; refer all work to your authorised **Coemar** service centre.
4. A good earth connection is essential for the proper functioning of the projector. Never connect the fixture if there is no earth connection.
5. Mains cables must not come into contact with other cables.
6. Do not operate the projector with wet hands or in an area where water is present.
7. The fixture must never be located in an exposed position, or in areas of extreme humidity.

### Safety:



1. The projector must always be installed with bolts, clamps, or other fixing devices which are suitably rated to support the weight of the projector.
2. Always use a secondary safety fixing device with chain or steel wire of a suitable rating to sustain the weight of the unit in case of failure of the principal fixing point.
3. The external surfaces of the unit, at various points, may reach 60°C. Never handle the unit until at least 10 minutes have elapsed since the LED was turned off.
4. Never install the fixture in an enclosed area lacking sufficient air flow; the room temperature must not exceed 35°C.
5. The projector contains electronic and electrical components which must under no circumstances be in contact with water, oil or any other liquid. Failure to do so will compromise the proper functioning of the projector.

---

## 2.2 Warranty conditions

1. The fixture is under warranty for 36 months from the purchase date against factory defec-tions.
2. Damage ought to unskillfulness, inappropriate use, or lack of suggested maintenance are excluded from the warranty.
3. Warranty expires when the projector is opened by unauthorized personnel.
4. Warranty doesn't include the replacement of the fixture.
5. Serial number and model of the fixture are necessary to retrieve informations and assistance from the dealer.

---

## 2.3 EC Norms

The projector meets all fundamental applicable EC requirements.

# 3. Product specifications

## 3.1 Technical characteristics

Power supply	90-230Vac, 50-60Hz
Maximum current	1 A a 230 VaC - 2.6 A a 90 Vac
Power factor	$\text{Cos}\phi = 0.9$
Power consumption	210 watt
Weight (without optic)	6 Kg - 13.2 lbs
Minimum ambient temperature	-20°C / -4°F
Maximum ambient temperature	+35°C / +95°F
IP rating	IP20

## 3.2 Dimensions

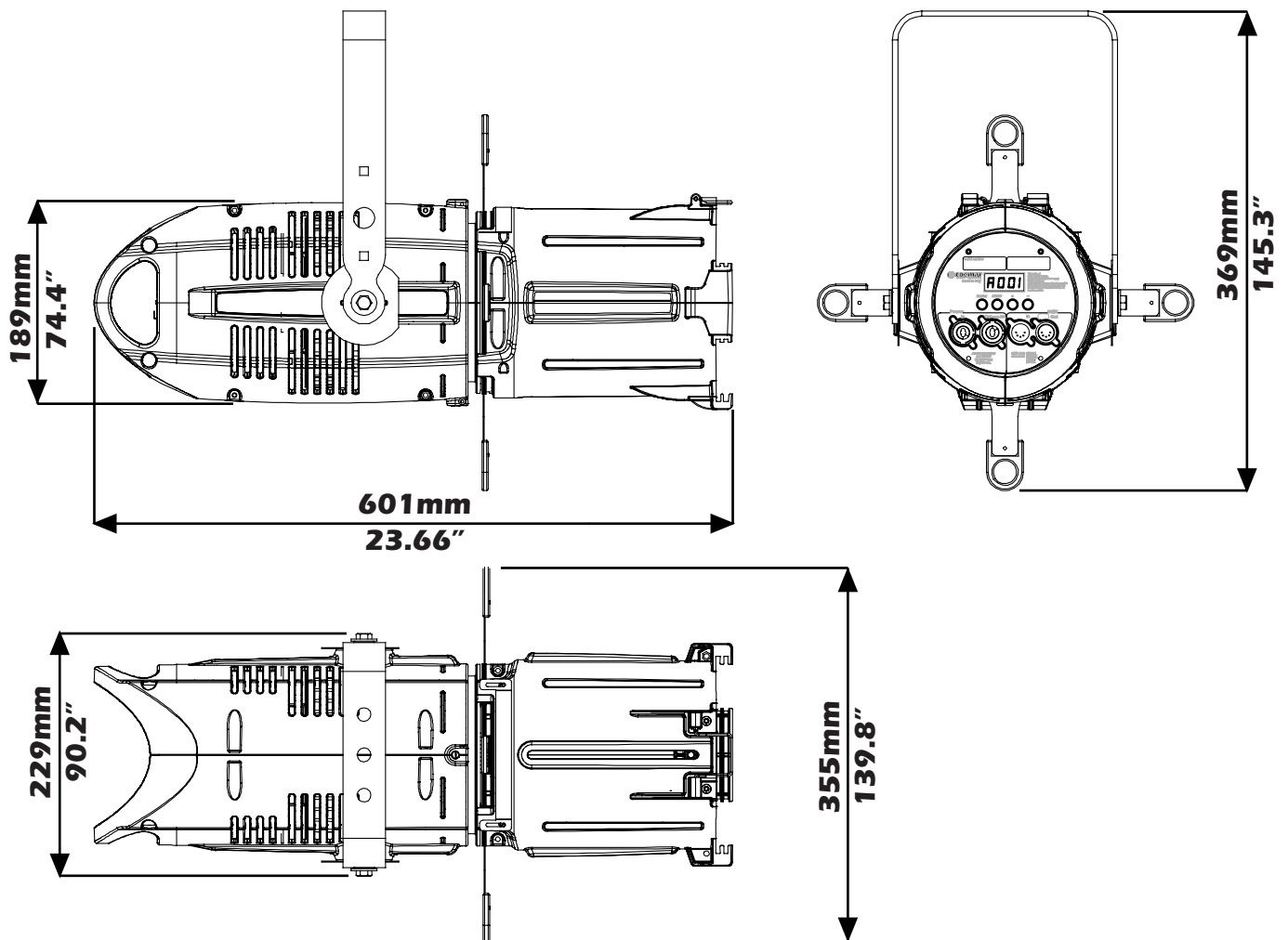

### 3.3 Unit's main components

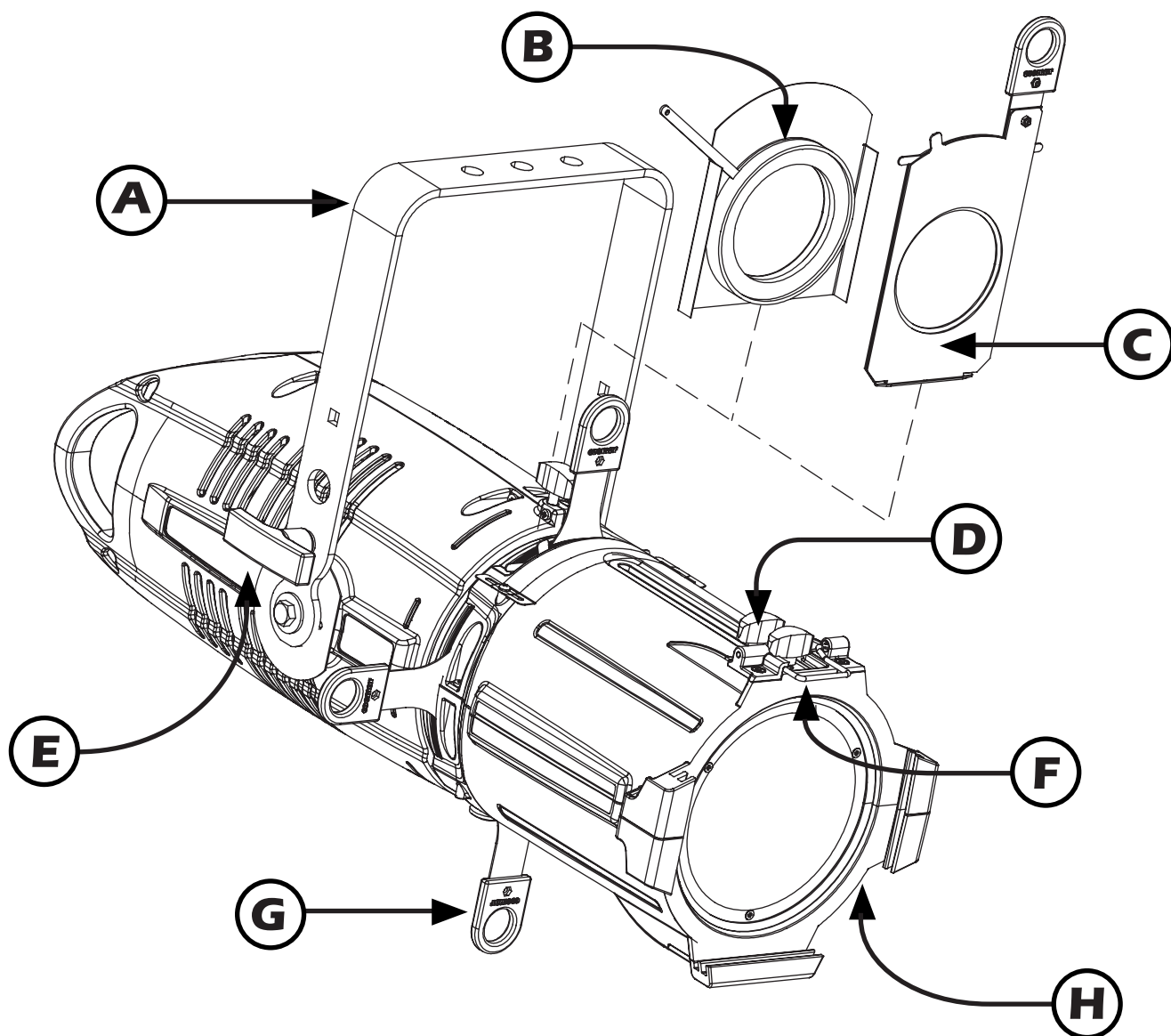

Components description	
<b>A</b>	Adjustable yoke
<b>B</b>	Iris (optional)
<b>C</b>	Gobo holder (optional)
<b>D</b>	Lens adjusting handles
<b>E</b>	Yoke locking handle
<b>F</b>	Gel frame locking spring
<b>G</b>	Profile blade
<b>H</b>	Interchangeable optic



### 3.4 Back panel description

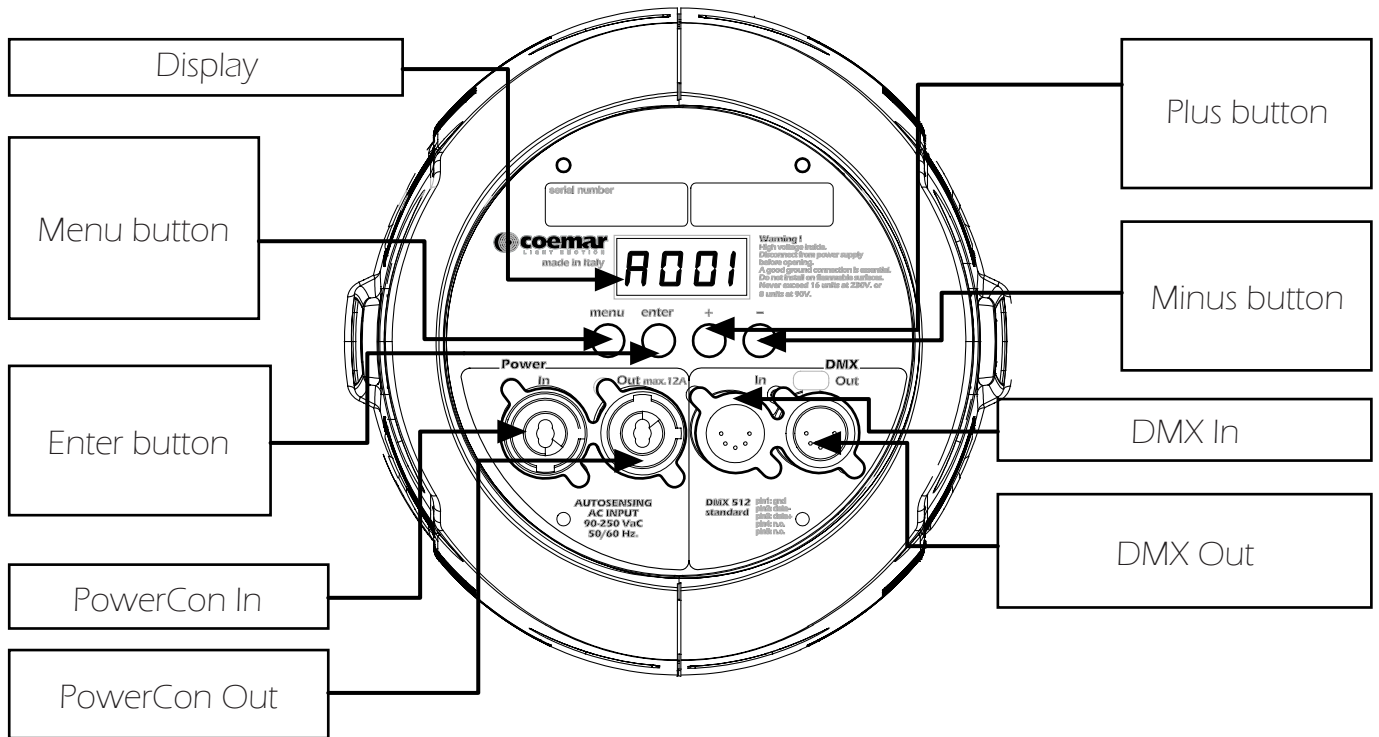

# 4. Installation

## 4.1 Optical installation

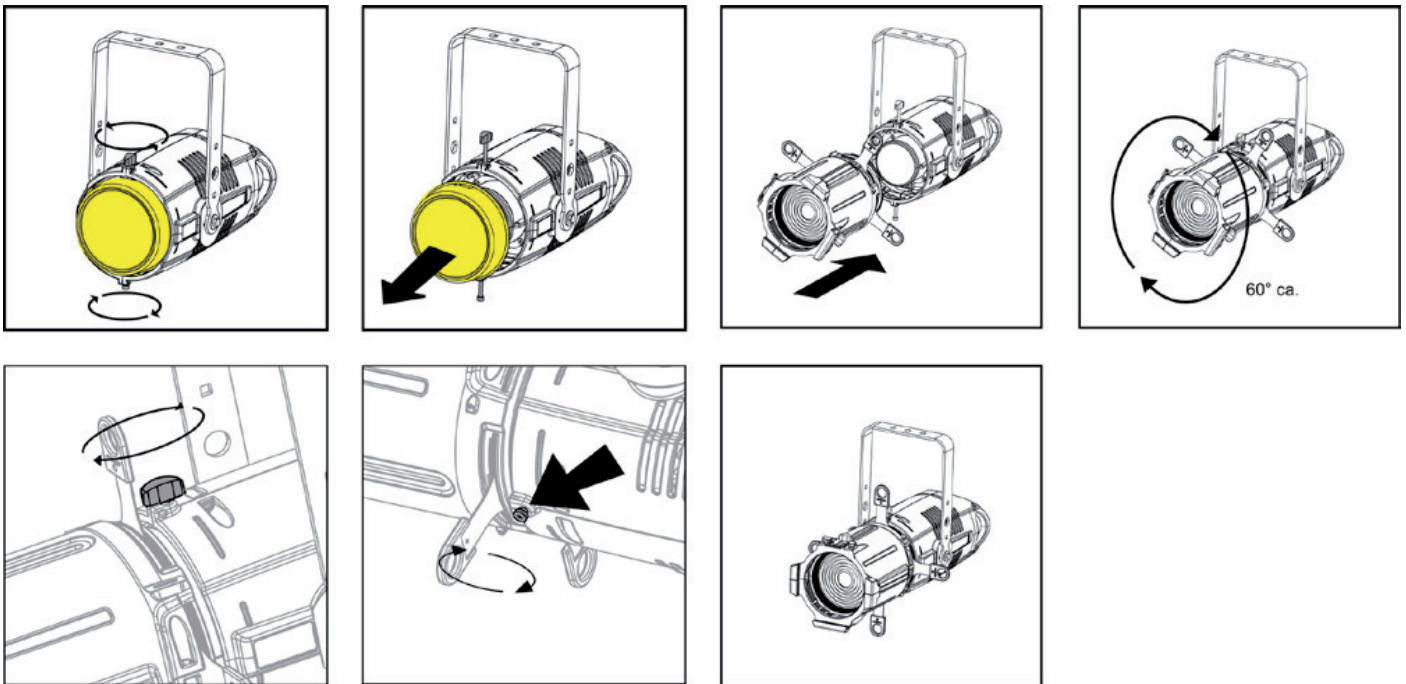

Remove the frontal cap by loosening the upper and lower screws enough to free the cap itself, set the optic's flange tilted about 60°. Insert the optic's flange into the body's receptacle and turn the optic 60° until it is firmly assembled to the projector body, free to rotate but not free to detach itself from the body. Ensure the optic to the body by tightening the two screws previously loosened.

### Warning!!

When the protective cap is removed, never lean the fixture facing down.  
The front lens can be seriously damaged.

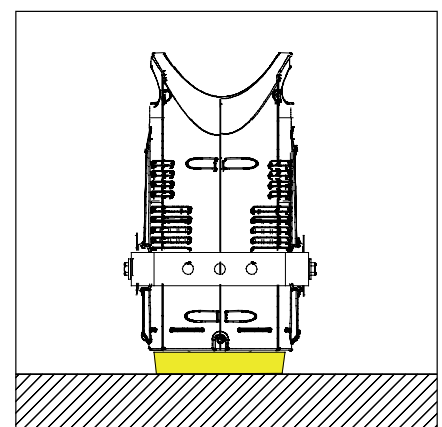
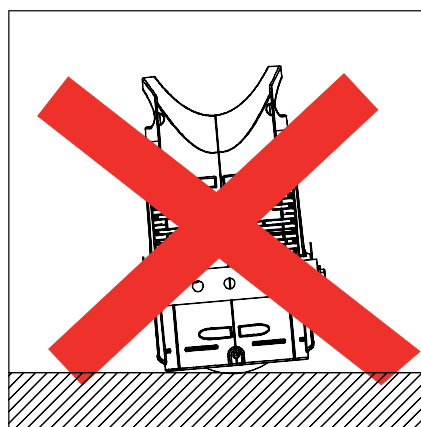
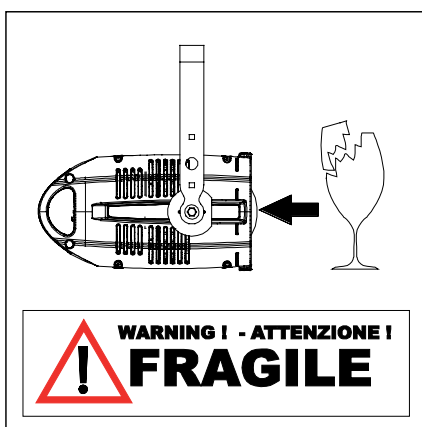

---

## 4.2 Mechanical installation

**LEDko VariWhite Series 2** may be hung from an appropriate structure in any position or on tripod. If hanging the fixture from a lighting truss or similar, we recommend the use of an appropriate clamp "A", as shown in the following diagram.

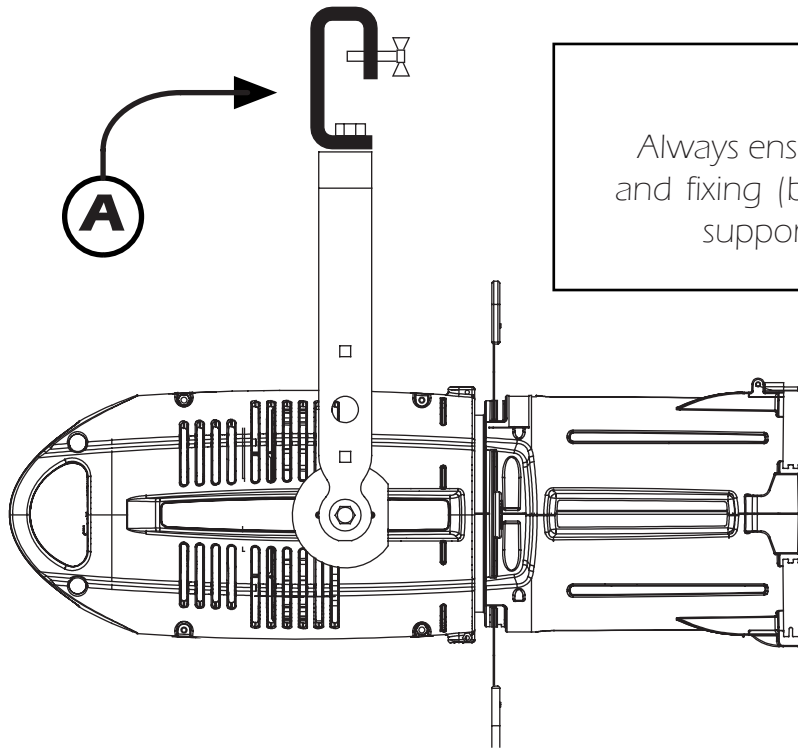

### **Warning!!**

Always ensure that your support structure and fixing (bolts, clamps, etc...) are rated to support the weight of the fixture.

---

## 4.3 Safety chain

When hanging **LEDko VariWhite Series 2** it is recommended to use a safety chain, as required by current legislation. The safety chain must pass through the handles of the unit and then attached to the structure.

If using steel cables and chains not **Coemar's** production, make sure they are suitable to support the weight of the unit according to normative UL/ETL (required: the weight of 6 complete devices for at least one hour).

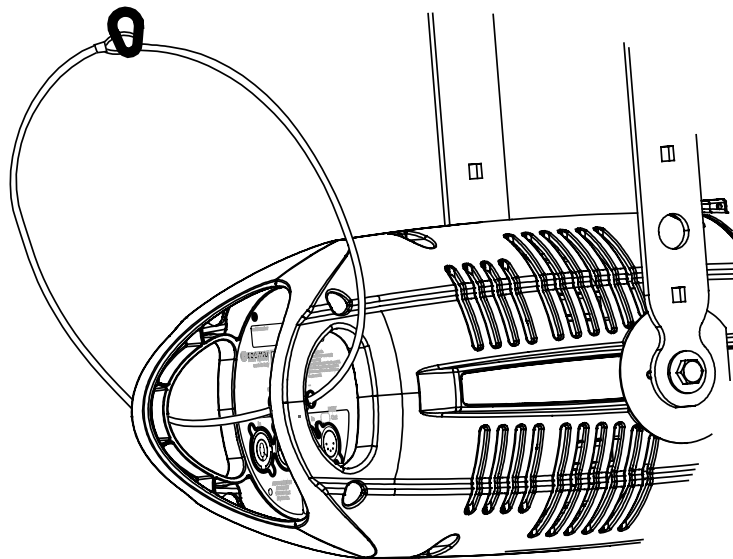

---

## 4.4 Adjusting unit's tilt

In order to adjust the tilt of the unit simply loose the side handle adjust the tilt and lock the yoke by tightening the handle again.

# 5. Powering up

## 5.1 Operating voltage and frequency

The unit may operate at voltage ranges from 90 to 230V<sub>aC</sub> at a frequency of 50 or 60 Hz. It is not needed to effect any setup procedures: **LEDko VariWhite Series 2** will automatically adjust its operation to suit any frequency or voltage within this range.

## 5.2 Connection to mains power

### Mains cable characteristics

The mains cable provided is thermally resistant, complying to the most recent International standards.

Note: in case of cable replacement, similar cable with comparable thermal resistant qualities must be used exclusively (cable 3 X 1,5  $\varnothing$  external 10 mm, rated 300/500V, tested to 2 KV, operating temperature -40°C + 180°C, Coemar cod. CV5311).

### Connection to mains power

**LEDko VariWhite Series 2** is equipped with two power connectors, one as input and one as output, which can be used to feed up to 8 (at 230 V<sub>aC</sub>) or 4 (90 V<sub>aC</sub>) fixtures.

The max absorption of **LEDko VariWhite Series 2** is reported in the following table:

- 230 V<sub>aC</sub> 1 A constant during normal exercise.
- 90 V<sub>aC</sub> 2.6 A constant during normal exercise.

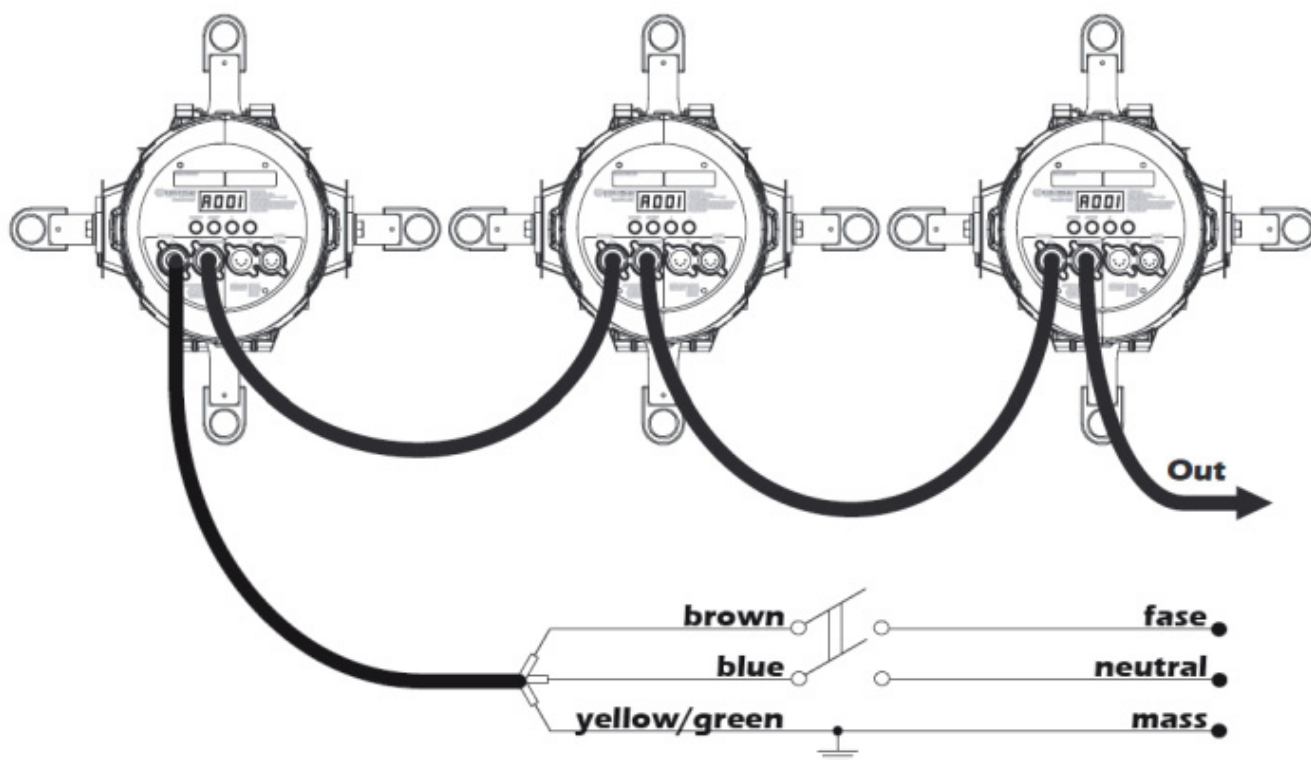

### **Warning!!**

- The use of a thermal/magnetic circuit breaker is recommended. Strict adherence to regulatory norms is strongly recommended.
- **LEDko VariWhite Series 2** should not be powered through a dimmer as this may damage the internal switching power supply.
- Prior to connecting the device to mains power, ensure that the mains characteristics are within the recommended range for the use of **LEDko VariWhite Series 2**.
- All cabling and connections should be carried out by a suitably qualified personnel.

# 6. Control signal connections

## 6.1 Control signal connection by XLR5 plugs

The digital control signal is transmitted to the projector via a two pole cable screened in according to the International standards for DMX 512 data transmission. The connection must be serial, using connectors XLR5 male and female located on the back of **LEDko VariWhite Series 2** labelled DMX512 IN e OUT.

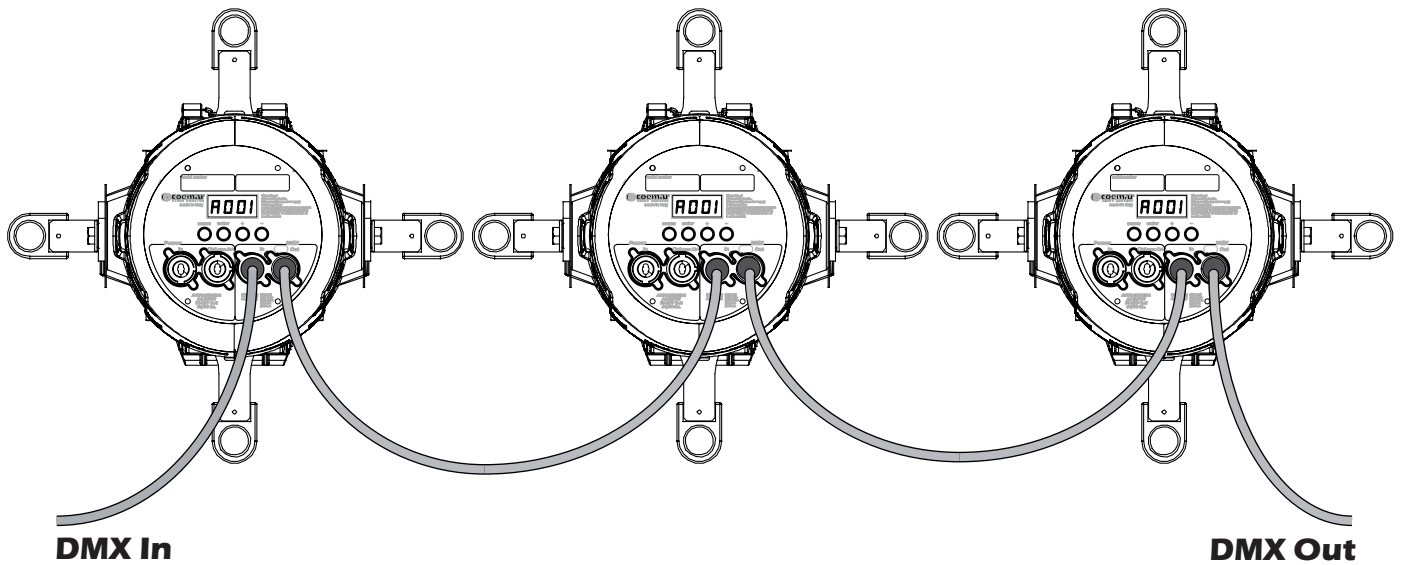

### Warning!

Make sure that screening and conductors are not in contact one another or with the metal housing of the connector.

Pin#1 and housing must never be connected to the power supply unit.

# 7. Turning on the projector

After having followed the preceding steps described, proceed with the power supply and turn on the projector connecting it to the mains power. The software version installed on the internal microprocessors will be shown on the display, suddenly it will show the current DMX addressing. If the address blinks, it means that the DMX signal has not been received. Check the connection cable and the mixer functioning.

## 7.1 DMX address of the unit

Each projector can use 6, 2 or 1 address channels for its complete operation and is controlled by a DMX 512 signal.

### DMX addressing

When powered up initially, each projector will show "A001", which indicates that the fixture will start responding from the first DMX channel; **LEDko VariWhite Series 2** also uses 6 DMX channels, which means that it will respond to the commands from channel 1 to channel 6 of your DMX 512 controller. Accordingly a second unit should be addressed as A007, a third one as A013 and so on. The operation must be carried out on every **LEDko VariWhite Series 2** which has an address different from A001.

### Altering the DMX address:

1. Press the + or – button until the display shows the required DMX address. The digits on the display will blink to indicate that the variation has not been registered.
2. Press the enter key to confirm your selection. The digits on the display panel will cease to blink and the projector will now respond to the new address.

**Note:** by holding the + or – button down the scrolling will be faster; thus allowing a faster selection

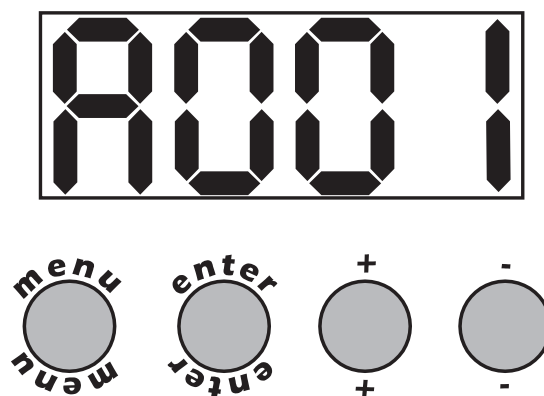

### Warning!

If you alter the DMX address with no DMX signal connected, the digits on the display panel will continue to flash even after you have pressed ENTER button to confirm the address.

# 8. DMX chart

## 8.1. DMX Chart 6 channels

channel	function	type of control	effect	decimal	percentage
1	master dimmer	proportional	adjust luminous output intensity from 0 to 100%	0 - 255	0% - 100%
2	dimmer fine	proportional	fine dimmer control 16 bit	0 - 255	0% - 100%
3	white temperature	step	3200 K	0 - 10	0% - 4%
			2700 K	11 - 16	4% - 6%
			2800 K	17 - 22	7% - 9%
			2900 K	23 - 28	9% - 11%
			3000 K	29 - 34	11% - 13%
			3100 K	35 - 40	14% - 16%
			3200 K	41 - 46	16% - 18%
			3300 K	47 - 52	18% - 20%
			3400 K	53 - 58	21% - 23%
			3500 K	59 - 64	23% - 25%
			3600 K	65 - 70	25% - 27%
			3700 K	71 - 76	28% - 30%
			3800 K	77 - 82	30% - 32%
			3900 K	83 - 88	33% - 35%
			4000 K	89 - 94	35% - 37%
			4100 K	95 - 100	37% - 39%
			4200 K	101 - 106	40% - 42%
			4300 K	107 - 112	42% - 44%
			4400 K	113 - 118	44% - 46%
			4500 K	119 - 124	47% - 49%
			4600 K	125 - 130	49% - 51%
			4700 K	131 - 136	51% - 53%
			4800 K	137 - 142	54% - 56%
			4900 K	143 - 148	56% - 58%
			5000 K	149 - 154	58% - 60%
			5100 K	155 - 160	61% - 63%
			5200 K	161 - 166	63% - 65%
			5300 K	167 - 172	65% - 67%
5400 K	173 - 178	68% - 70%			
5500 K	179 - 184	70% - 72%			
5600 K	185 - 190	73% - 75%			
5700 K	191 - 196	75% - 77%			
5800 K	197 - 202	77% - 79%			
5900 K	203 - 208	80% - 82%			
6000 K	209 - 214	82% - 84%			
6100 K	215 - 220	84% - 86%			
6200 K	221 - 226	87% - 89%			
6300 K	227 - 232	89% - 91%			
6400 K	233 - 238	91% - 93%			
6500 K	239 - 244	94% - 96%			
5600 K	245 - 255	96% - 100%			
4	white temperature fine	step	no effect	0	0%
		proportional	fine white temperature control (from temperature selected to the previous step)	1 - 126	1% - 49%
		step	no effect	127 - 128	50% - 50%
		proportional	fine white temperature control (from temperature selected to the following step)	129 - 254	51% - 99%
		step	no effect	255	100%



5	strobe	step	no effect	0 - 9	0% - 4%
		proportional	variable speed strobing effect, from slow to fast	10 - 57	4% - 22%
		step	stop strobe	58 - 59	23% - 23%
		proportional	sequenced pulse effect, slow closing, fast opening (variable speed pulsing, from slow to fast)	60 - 108	24% - 42%
		step	stop strobe	109 - 110	43% - 43%
		proportional	sequenced pulse effect, fast closing, slow opening (variable speed pulsing, from slow to fast)	111 - 159	44% - 62%
		step	stop strobe	160 - 161	63% - 63%
		proportional	random strobe effect with variable speed from slow to fast	162 - 207	64% - 81%
		step	stop strobe	208 - 209	82% - 82%
		proportional	random strobe effect with variable speed from slow to fast	210 - 255	82% - 100%
6	special functions	step	park, no effect	0 - 9	0% - 4%
			600Hz	10 - 84	4% - 33%
			fan at low-noise speed	85 - 96	33% - 38%
			fan at auto-silent speed	97 - 108	38% - 42%
		proportional	fan speed control from minimum to maximum	109 - 120	43% - 47%
		step	fan at maximum speed	121 - 133	47% - 52%
			enables the automatic display blackout	134 - 185	53% - 73%
			disables the automatic display blackout	186 - 199	73% - 78%
			LED control frequency tuning 1000Hz	200 - 205	78% - 80%
			LED control frequency tuning 3000Hz	206 - 211	81% - 83%
			LED control frequency tuning 6000Hz	212 - 217	83% - 85%
			LED control frequency tuning 8000Hz	218 - 223	85% - 87%
			LED control frequency tuning 10000Hz	224 - 229	88% - 90%
			LED control frequency tuning 12000Hz	230 - 235	90% - 92%
			LED control frequency tuning 14000Hz	236 - 241	93% - 95%
			LED control frequency tuning 16000Hz	242 - 247	95% - 97%
			LED control frequency tuning 19000Hz	248 - 255	97% - 100%
<p><b>Note: the one channel function mode can be selected through the DMX function menu. The color of the light will be the last selected when changing mode</b></p>					

## 8.2. DMX Chart 2, 1 channels

channel		function	type of control	effect	decimal	percentage
1	1	master dimmer	proportional	adjust luminous output intensity from 0 to 100%	0 - 255	0% - 100%
2	-	white temperature	step	3200 K	0 - 10	0% - 4%
				2700 K	11 - 16	4% - 6%
				2800 K	17 - 22	7% - 9%
				2900 K	23 - 28	9% - 11%
				3000 K	29 - 34	11% - 13%
				3100 K	35 - 40	14% - 16%
				3200 K	41 - 46	16% - 18%
				3300 K	47 - 52	18% - 20%
				3400 K	53 - 58	21% - 23%
				3500 K	59 - 64	23% - 25%
				3600 K	65 - 70	25% - 27%
				3700 K	71 - 76	28% - 30%
				3800 K	77 - 82	30% - 32%
				3900 K	83 - 88	33% - 35%
				4000 K	89 - 94	35% - 37%
				4100 K	95 - 100	37% - 39%
				4200 K	101 - 106	40% - 42%
				4300 K	107 - 112	42% - 44%
				4400 K	113 - 118	44% - 46%
				4500 K	119 - 124	47% - 49%
				4600 K	125 - 130	49% - 51%
				4700 K	131 - 136	51% - 53%
				4800 K	137 - 142	54% - 56%
				4900 K	143 - 148	56% - 58%
				5000 K	149 - 154	58% - 60%
				5100 K	155 - 160	61% - 63%
5200 K	161 - 166	63% - 65%				
5300 K	167 - 172	65% - 67%				
5400 K	173 - 178	68% - 70%				
5500 K	179 - 184	70% - 72%				
5600 K	185 - 190	73% - 75%				
5700 K	191 - 196	75% - 77%				
5800 K	197 - 202	77% - 79%				
5900 K	203 - 208	80% - 82%				
6000 K	209 - 214	82% - 84%				
6100 K	215 - 220	84% - 86%				
6200 K	221 - 226	87% - 89%				
6300 K	227 - 232	89% - 91%				
6400 K	233 - 238	91% - 93%				
6500 K	239 - 244	94% - 96%				
5600 K	245 - 255	96% - 100%				

# 9. Display panel functions

## 9.1 Quick guide to menu

To access the functions menus just press the MENU button. Then press + or – buttons to scroll the pages and press the ENTER button to access to any other function.

By suitably using all the functions of **LEDko VariWhite Series 2**, which can be activated through its display panel, it is possible to change some of the parameters and to add some functions. Changing the preset settings made by **Coemar** can vary the functions of the projector so that it will respond differently to the controller; therefore carefully read about the functions described here before carrying out any possible selection.

## 9.2 Rapid count

Through the display panel of **LEDko VariWhite Series 2** it is possible to quickly change the various numbers displayed for the different functions in the following 3 manners:

1. Pressing the + or – buttons will cause the count to be quicker.
2. Pressing first + and then – and then holding them down simultaneously will cause the numbers to jump to the highest value.
3. Pressing first – and then + and then holding them down simultaneously will cause the number to jump to the lowest value.

## 9.3 Main functions menu

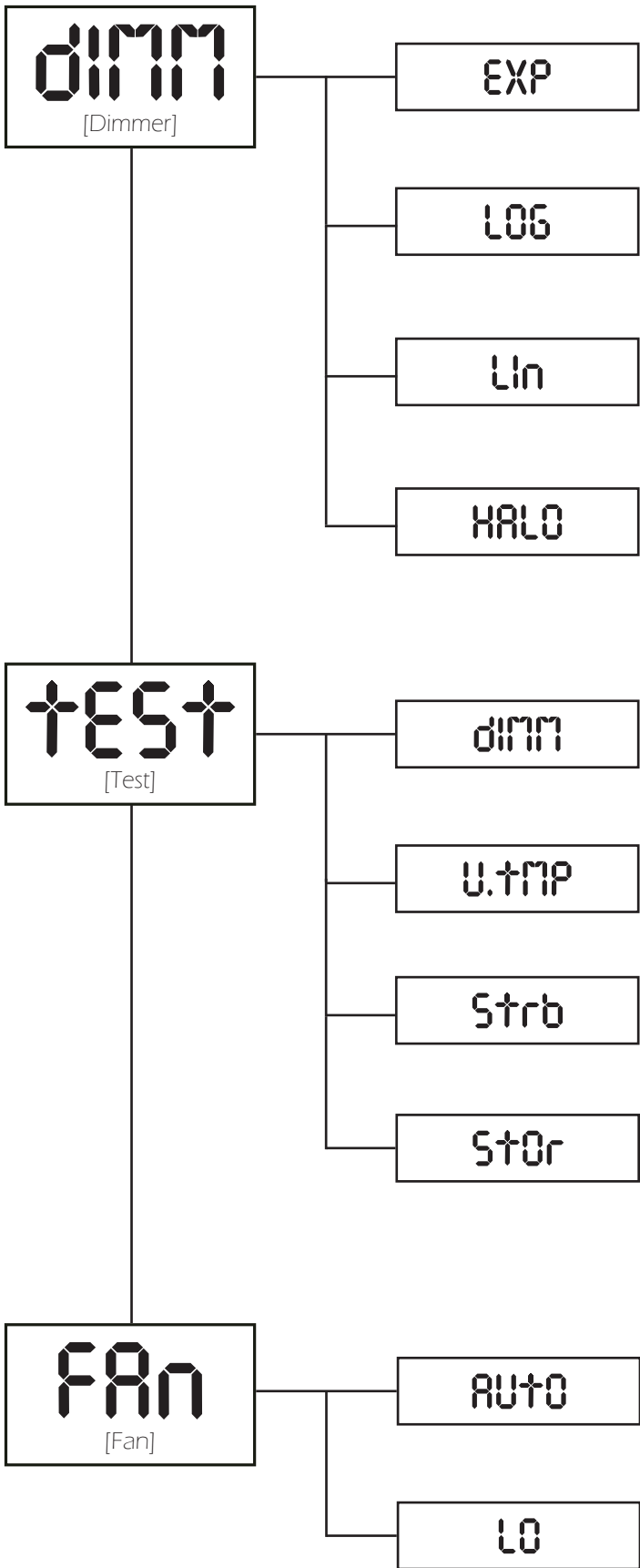

### Dimmer:

It allows the selection of different dimmer curves: exponential (default), logarithmic, linear and halogen;

### Test:

Allows to manually set the DMX channels controlled by a DMX console:

- **Dimmer:** sets the luminous intensity;
- **White temperature:** allows to change manually the white temperature;
- **Strobe:** manually sets the strobe DMX channel;
- **Store:** stores the modifications that will be set at the next times the fixture will be turned on.

### Fan Speed:

- **Auto:** balance the fan speed to meet the maxim silence without compromising the light performance;
- **Low noise:** sets the minimum fan speed to ensure a silent performance at the expense of light output (the total power will decrease to 160 W).

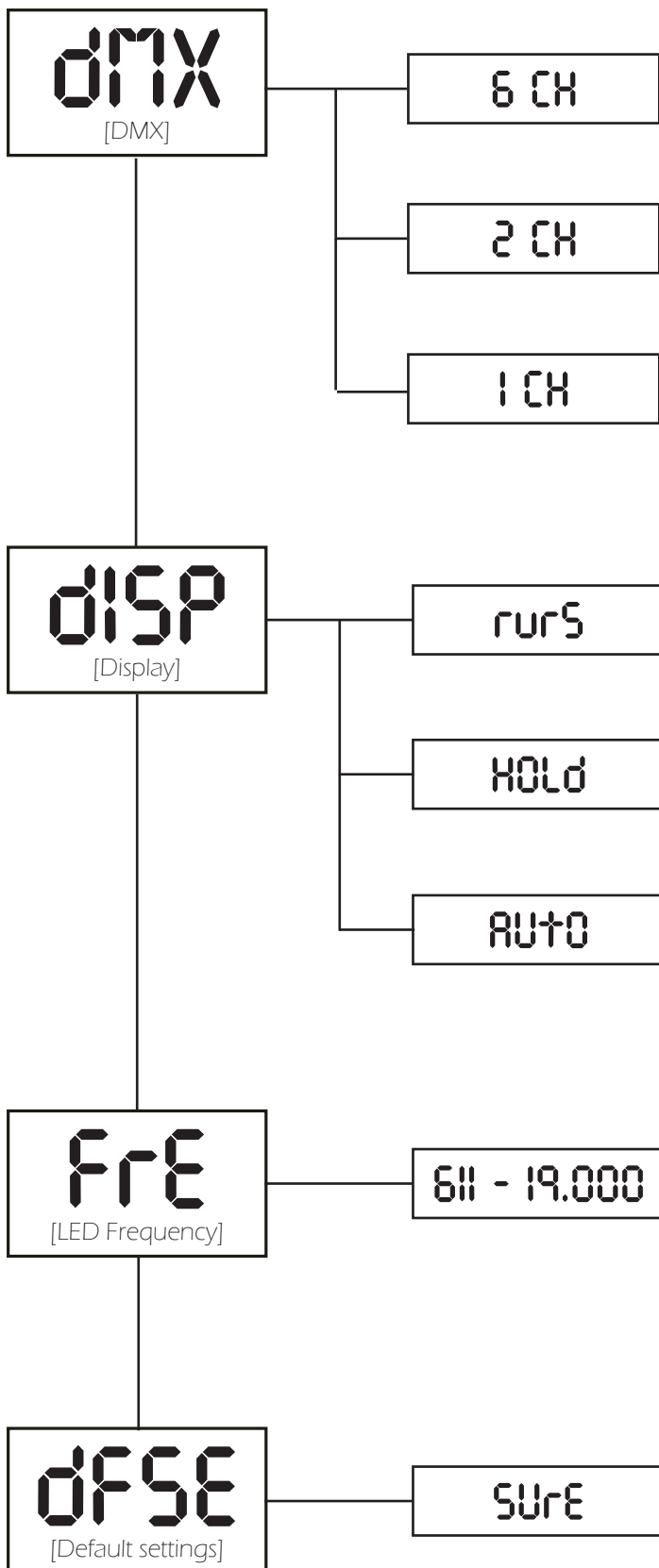

### DMX channels:

Allows to choose the number of channels with which operate in DMX mode.

### Display functions:

Changes the display settings:

- **Reverse:** rotates the display of 180°;
- **Hold** Sets or disables the automatic display lock function that occurs after 10 seconds of inactivity;
- **Auto:** Sets or disables the automatic display turn off function, which would occur after 10 seconds of inactivity;

**Note:** The AUTO and HOLD function become active only when the DMX address selection is displayed (A001). The effect of AUTO and HOLD trigger after 10 seconds of keyboard inactivity. To turn on the display it is enough to push a button, to unlock the keyboard it is necessary to hold any button down for a few seconds.

### LED Frequency:

It allows to set the flickering frequency from 611 to 19.0000 Hz besides the default value. (DMX signals goes ahead this setting).

### Default Settings:

Allows to restore the factory default of the fixture, with exception of DMX address and LED alignment.

## 9.4 Measures menu (MEAS)

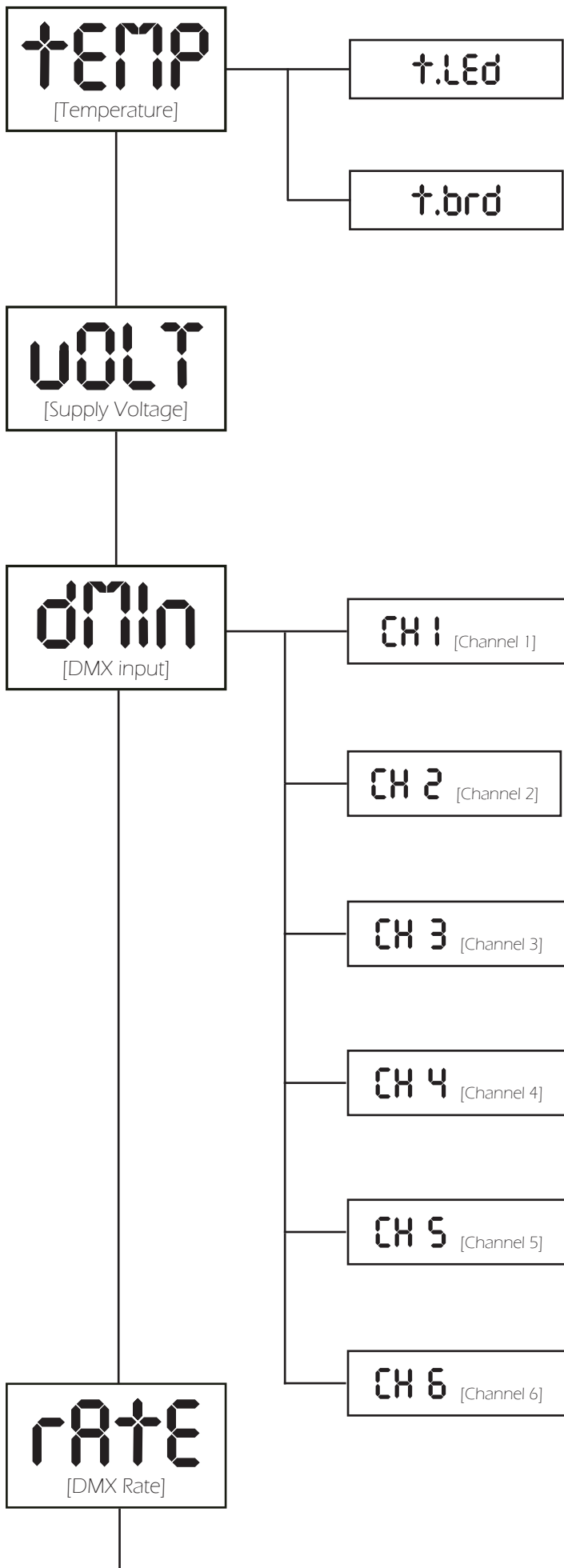

### Temperature:

Shows the current temperature values:

- **LED:** shows the LED module temperature;
- **Board:** shows the electronic board temperature.

### Volt:

Shows the power supply voltage.

### DMX Input:

Shows the value of the DMX channels received by the fixture on every channel that the fixture occupies on the line.

### Rate:

Shows the refresh rate of the DMX signal sent by the console.

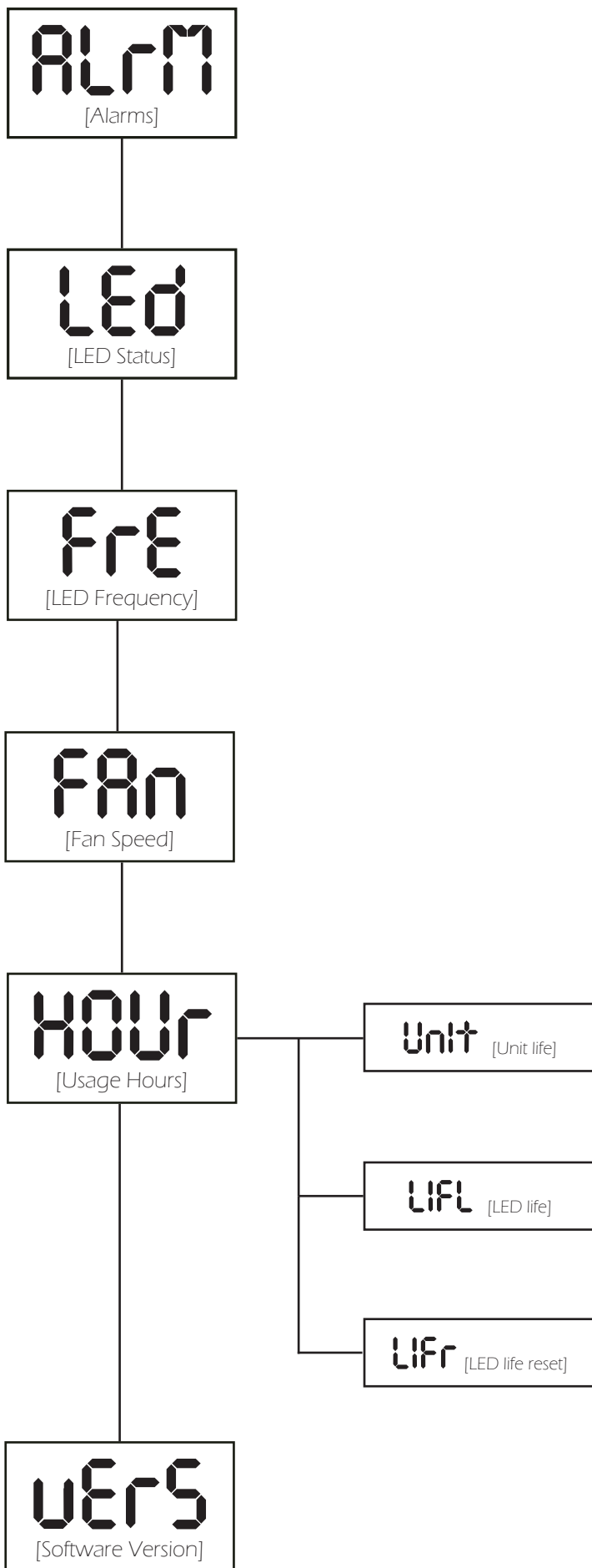

**Alarm:**

This menu shows the alarm statuses if there is any.

**LED:**

Shows the percentage value of the LED status.

**Frequency:**

Shows the operating frequency of the LED (611 Hz as default).

**Fan speed:**

Shows the voltage in which the fan is operating.

**Usage hours:**

Shows the hour counter of the fixture:

- **Unit:** shows the overall hours of life of the fixture;
- **LED life:** shows the overall LED module life;
- **LED life reset:** shows the overall LED module life currently installed.

**Note:** this items can be reset in case of LED module replacement;

**Software version:**

Shows the software version currently installed in the fixture.

## 9.5 Electronic alignment of the leds

The display panel of **LEDko VariWhite Series 2** allows the electronic alignment of the LEDs, this procedure is performed by **Coemar** at the time of testing, this procedure may be useful for special effects or in case of replacement of internal components (PCBs, LEDs, etc...).

Altering the settings made by **Coemar** may radically alter the operation of the projector's functions. Carefully read the following prior to attempting any changes.

### Warning!!

This chapter should be considered for the exclusive use of technicians and qualified personnel.

### Warning!!

This menu can only be accessed in the **DF.SE.** [Default Settings] menu by pressing at the same time **ENTER** and **MENU** buttons. This menu shall be accessed only by authorized technicians.

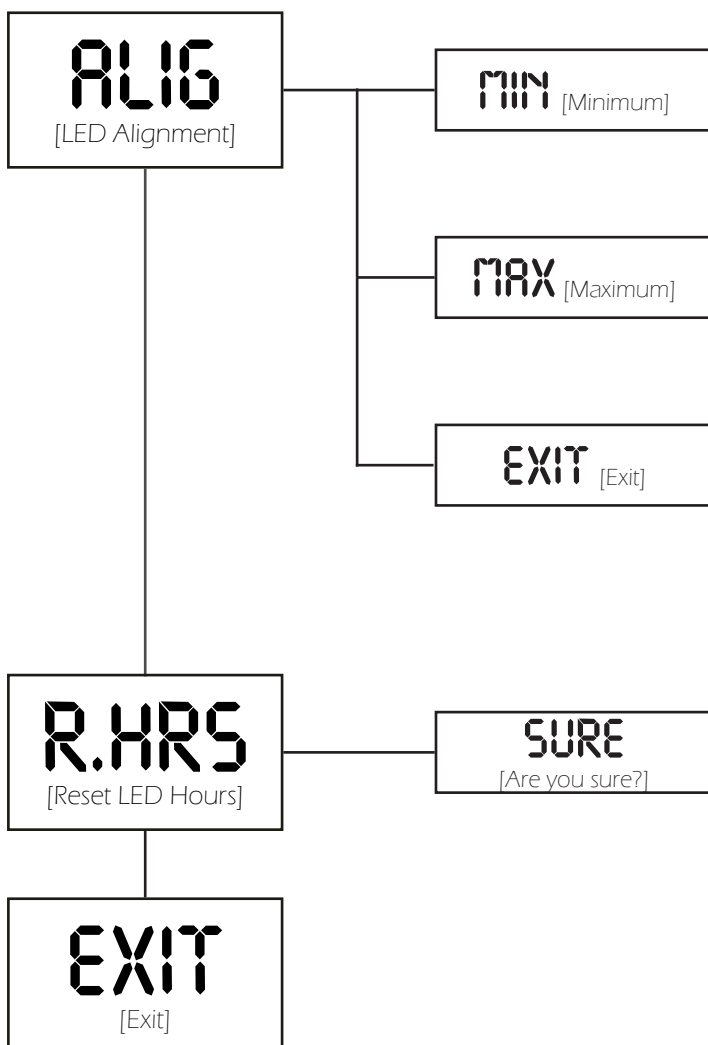

### LED alignment:

This item allows to align the minimum and the maximum level of intensity of the LEDs:

- **Minimum:** raise or lowers the minimum intensity to level the dimming between the fixtures;
- **Maximum:** aligns the maximum output level between each fixture;
- **Exit:** exits the menu and stores the changes;

### Reset hours:

Allows to erase the hours of operation of the LED module in case of replacement;



---

## 9.6 Special functions of the fixture

### Storing the DMX signal

To use the fixture without an active DMX console it is possible to store the DMX settings in two ways:

- Through the **TEST** menu;
- Disconnecting the DMX signal when the fixture is on. When the signal is unconnected the fixtures stores the signal;

### Automatic fan standby

To decrease the noise and the power consumption the cooling fan turns off after 10 minutes of fixture inactivity.

---

## 9.7 Error messages

If a malfunction occurs, **LEDko VariWhite Series 2** has a self-diagnostic system that will show the error message on the display. The following table will explain in detail the most common errors. If, despite of suggested intervention, the problem persists, call the **Coemar** Service Center.

Error code	Description
<b>noal</b> [No Alarm]	<b>No Alarm</b> The projector self-diagnostic routine didn't find any issue.
<b>DTER</b> [Data Error]	<b>Data error</b> Initial data loading has failed the projector loaded the default data settings: restart the fixture again, and if the error persists contact the <b>Coemar</b> assistance center.
<b>ADER</b> [Address Error]	<b>Address error</b> The projector does not receive all channels of DMX needs to function properly. Check the DMX address indicated on the display and the number of channels generated by the mixer control. We recall in this connection that some controllers do not generate all the 512 channels.
<b>LED</b> [LED Error]	<b>LED error</b> Auto diagnostic routine found that the LED module may damaged, contact Coemar assistance for the module replacement. <b>IMPORTANT:</b> To ensure the sensor is giving correct readings, set the LED to the maximum light output level.

# 10. Accessories and spare parts

LEDko VariWhite Series 2 is a very versatile fixture, optional accessories for its customization are available under request:

<b>Accessory name</b>	<b>Code</b>
Front barrel for lens tube with burnished blades	BC10011A200
Profile 5°, lens tube	BC10011A041
Profile 10°, lens tube	BC10011A042
Profile 14°, lens tube	BC10011A023
Profile 19°, lens tube	BC10011A012
Profile 26°, lens tube	BC10011A013
Profile 36°, lens tube	BC10011A015
Profile 50°, lens tube	BC10011A016
Profile 70°, lens tube	BC10011A024
Profile 90°, lens tube	BC10011A025
Profile Zoom 15°- 35°	BC10011A017
Profile Zoom 25°- 50°	BC10011A019
Profile Zoom 28°- 40°	BC10011A003
Soft Profile Fresnel Zoom 14°- 40°	BC10011A002
Soft Profile PC Zoom 11°- 38°	BC10011A001
4 leaf barndoor	ACO4202
Gobo frame holder	BC10011A006
Iris	BC10011A010
Donut (190.5 mm)	BC10011A028
Half Top Hat (190.5 mm)	BC10011A027
Top Hat (190.5 mm)	BC10011A029
Color Frame Holder (190 mm)	BC10011A040
Donut (185 mm)	BC10011A036
Half Top Hat (185 mm)	BC10011A035
Top Hat (185 mm)	BC10011A037
Color Frame Holder (185 mm)	ACO4204

Donut (159 mm)	BC10011A032
Half Top Hat (159 mm)	BC10011A031
Top Hat (159 mm)	BC10011A033
Colour Frame Holder (159 mm)	BC10011A021
(Gobo Slot) Glass template holder (93.6 mm)	BC10011A030
Hook clamp, 48-51 mm, max. load 20 Kg.	BC10011A047
Light clamp silver, 48-51 mm, max. load 75 Kg.	BC10011A045
Light clamp black, 48-51 mm, max. load 75 Kg.	BC10011A046
Clamp silver, flat 13-30 mm/ø 15-50 mm, max. load 20 Kg.	BC10011A043
Clamp black, flat 13-30 mm/ø 15-50 mm, max. load 20 Kg.	BC10011A044

All the components of **LEDko VariWhite Series 2** are available as spare parts from your **Coemar** dealer or Service. Accurate description of the fixture, model number and type will assist us in providing for your requirements in an efficient and effective manner.

# 11. Maintenance

---

## 11.1 Firmware update

The firmware of **LEDko VariWhite Series 2** can be updated through the RDM protocol (ANSI E1.20). Contact Coemar assistance to receive the software and the device updater.

---

## 11.2 Periodic cleaning

### Lenses

Even a thin layer of dust can reduce the luminous output and alter the consistency of the beam. Regularly clean all filters and lenses using a soft cotton cloth, dampened with a special lens cleaning solution.

### Cleaning of the unit

Use a soft brush or a common vacuum cleaner or a source of compressed air for removing dust. For the cleaning of the housing use a soft cloth and a non-aggressive cleaner. Check that the internal fans and heat exchanger must be perfectly clean.

---

## 11.3 Periodic controls

### Mechanical components

Check the correct working of the mechanical parts and, if needed, replace them. Make sure the projector is not mechanically damaged. If necessary, replace the worn parts.

### Electrical components

Check all electrical connections, in particular for correct grounding and correct attachment of all extractable connectors. Press the connectors if necessary and reposition as before.

---

## 11.4 Fuses

**LEDko VariWhite Series 2** has an automatic fuse that in most cases does not need to be replaced.

## 12. F.A.Q. and answers

The following list shows common issues that may be simply solved. If issues persist, the unit must be repaired by a qualified personnel or just contact your **Coemar** service near you.

Question	Possible solution
<b>LEDko VariWhite Series 2</b> does not emit light	<b>Projector not powered on:</b> <ul style="list-style-type: none"><li>• Make sure the power cord is plugged in or test the input voltage;</li></ul> <b>Wrong DMX address:</b> <ul style="list-style-type: none"><li>• Check the DMX Address setting and the output signal of the controller;</li></ul>
<b>LEDko VariWhite Series 2</b> is not responding to DMX signal	<b>DMX signal may not reach LEDko VariWhite Series 2:</b> <ul style="list-style-type: none"><li>• Inspect the cable connection, correct poor connections or inefficient repair or replace damaged cables;</li><li>• Check DMX address of the unit;</li></ul>

## User notes

A series of horizontal dotted lines for writing notes.



**Information on disposal of the equipment**

The equipment at the end of its useful life must be disposed of at an appropriate recycling center for waste electrical and electronic equipment. The treatment and disposal of environmentally friendly, helps prevent potential negative environmental and health and promote the reuse and / or recycling of materials making up the equipment. Illegal disposal by the user includes the application of administrative sanctions provided by law.



**Coemar Lighting s.r.l.**

Via Carpenedolo 90  
46043 Castiglione delle Stiviere, Mantova, Italy  
phone. +39 0376/1514412 - fax +39 0376/1514380  
info@coemar.com

**Coemar** reserves the right to effect modifications without notification